

# AND WHO IS USELESS NOW?

Ondřej Holba

## TECHNICAL RIDER

### DURATION:

- 50 min. without intermission

### STAGE:

- ideal size: 12m(width) x 12m (depth) x 4,5m (height) – audience included
- 4x4m black dance floor (the company will bring)
- audience rises around the stage (elevation increases by at least 40cm)
- no curtains, possibility of black backdrop
- we need to hang the LED frame to 3,8 height (10 kg) – see the light plot
- we need to hang the LED box to 3,8 height (3kg) – see the light plot
- stage has to be visible from livepost

### LIGHTS:

- 5x PC 1000W + barndoors
- 2x profile ETC S4 zoom 25–50° 750W
- 8x PAR 64 cp62 + gel frames
- 5x PAR 64 cp61 + gel frames
- 2x LED frame 4x4m (the company will bring)
- 12x dimmer channel 2 kW
- DMX 5 pin connection to ENTTEC USB DMX PRO (the company will bring)
- DMX 3 pin connection on the lighting grid
- DMX 3 pin connection on the ground
- 2x 230V plug on the lighting grid (for LED frame and LED box)
- 1x 230V plug on the ground (for LED frame)
- 3x 4,5m aluminium pipes (if the theater does not have, the company will bring it)

### SOUND:

- 2x 6,3 jack cable to connect soundcard (the company will bring)
- 4 speakers in each corner of the stage – see the light plot

### TIME TABLE:

09:00 – 09:30	load in
09:30 – 11:00	set up of lights, sound, black marley, top led frame
11:00 – 13:00	set up of ground led frame, focus of lights
13:00 – 14:00	Preparation of robots
14:00 – 15:00	Lunch break
14:00 – 16:00	Finalization, patch, sound check
16:00 – 16:30	technical run
16:30 – 17:30	warm up, rehearsal
17:30 – 18:00	cleaning, stage preparation
18:00 – 19:00	break
20:00	house is open (performer at the stage)
20:00 – 20:50	show
21:00 – 22:30	strike down

**It's possible to adapt the requirements for each venue, but everything has to be discussed and confirmed with technical manager:**

**Martin Hamouz**  
hamouz.m@gmail.com  
+420 733 364 922

# AND WHO IS USELESS NOW?

Ondřej Holba

## LIGHTPLOT

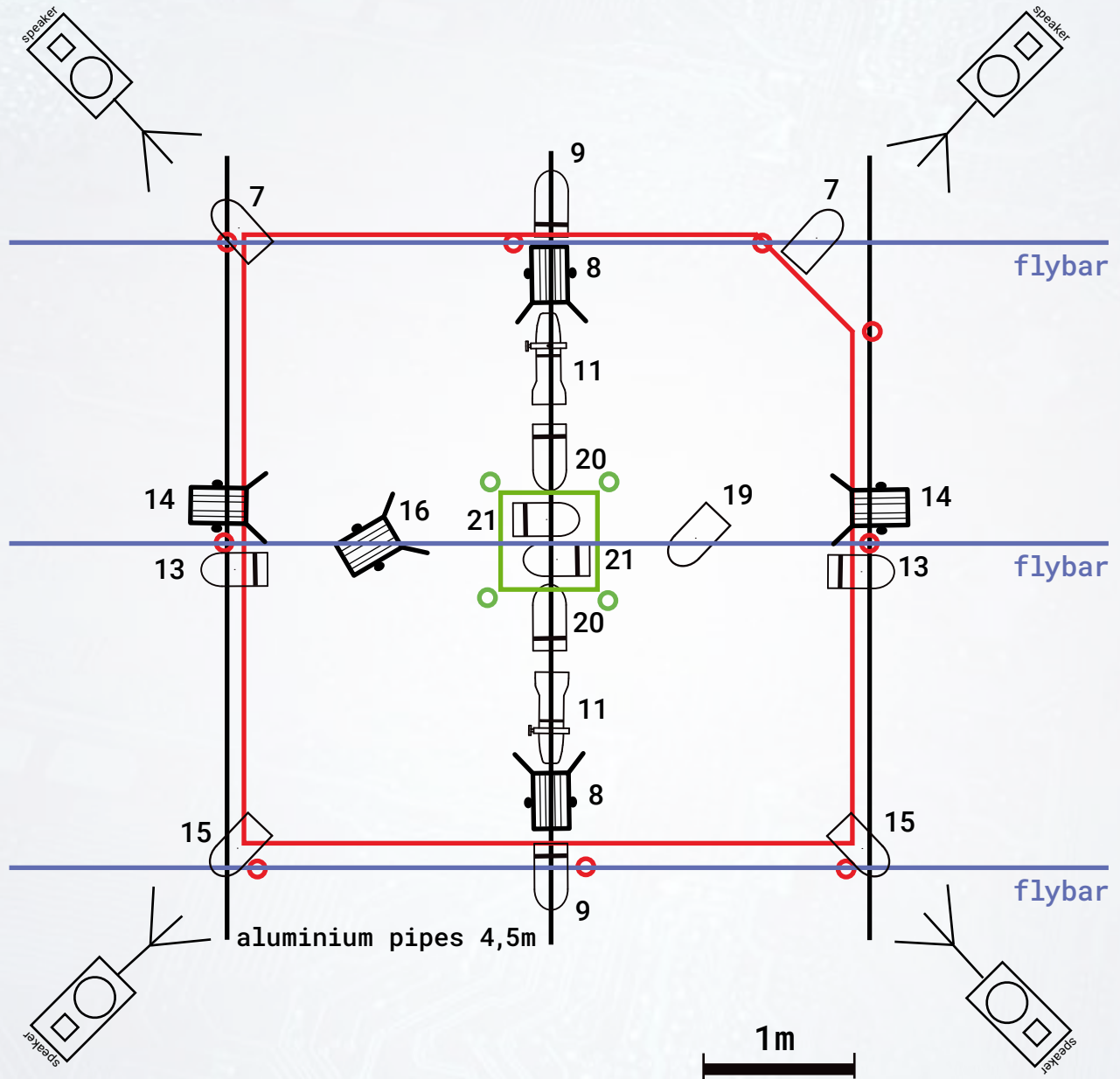

### legend



PC 1000W

5x



PAR 64  
CP61

5x



Aluminium LED light construction  
4x4 meters, 10 kg, 3,8 m above the floor



Wooden LED light construction  
0,5x0,5 meters, 3 kg, 3,8 m above the floor

8x



Suspension points



ETC S4 36°  
750 W

2x



PAR 64  
CP62

**Martin Hamouz**  
hamouz.m@gmail.com  
+420 733 364 922

# AND WHO IS USELESS NOW?

Ondřej Holba

## STAGE AND AUDIENCE

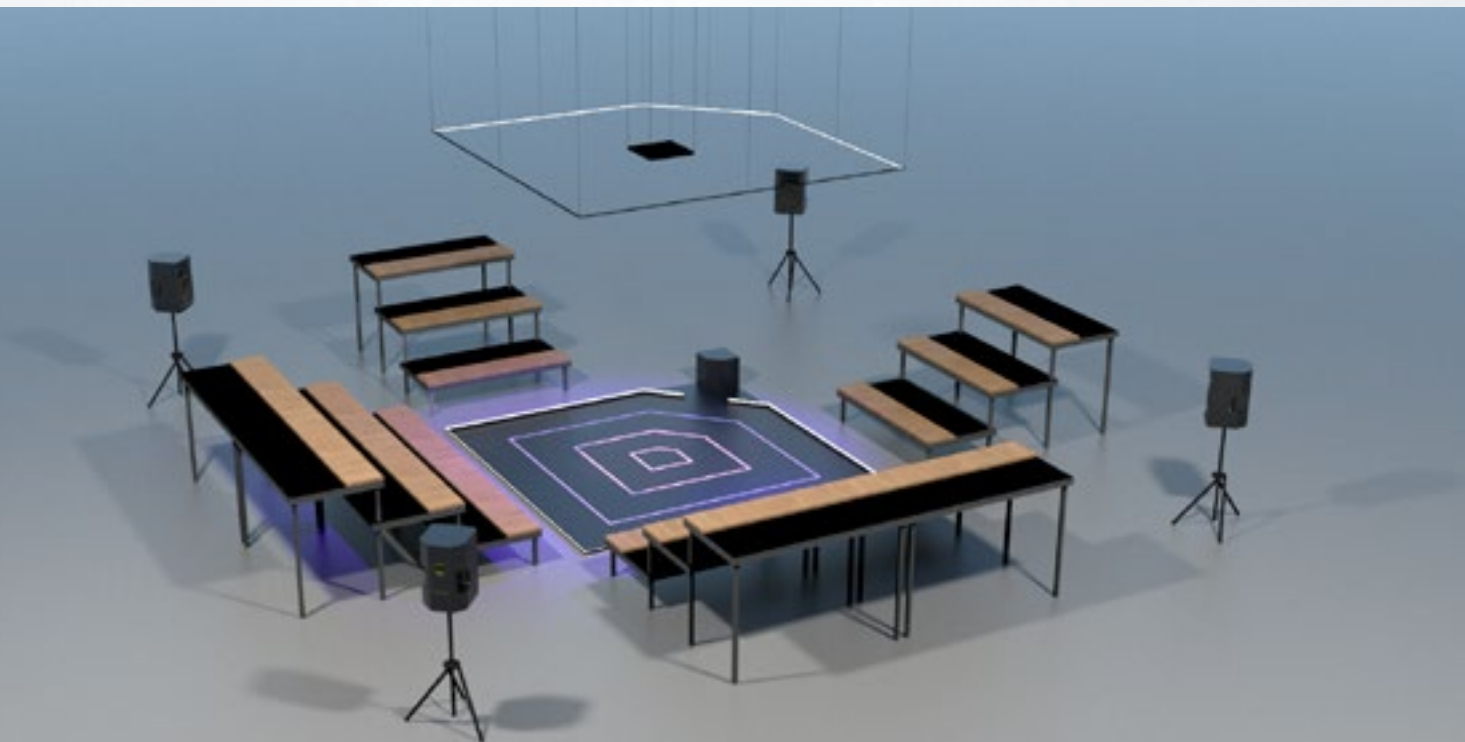
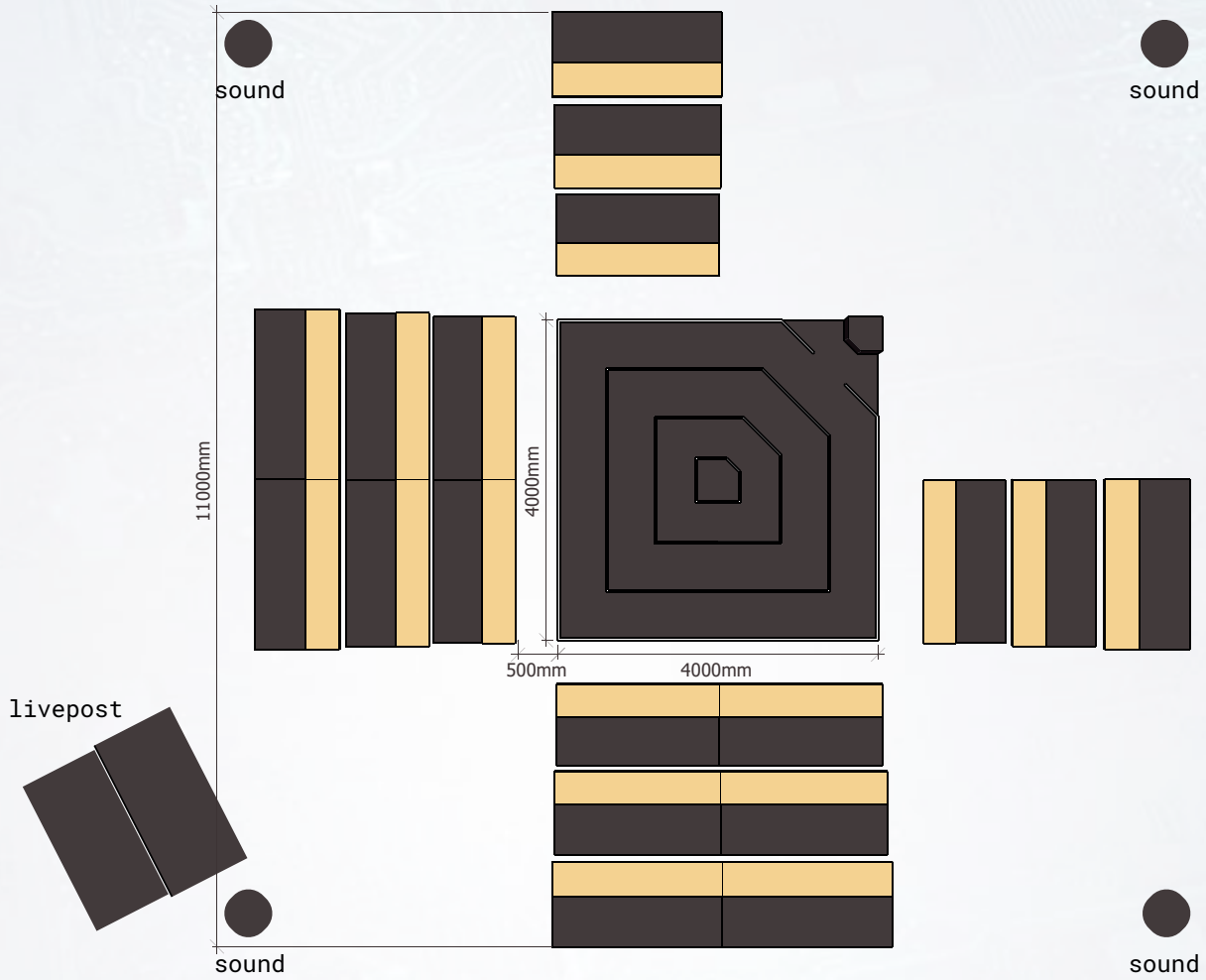

# AND WHO IS USELESS NOW?

Ondřej Holba

## STAGE AND AUDIENCE POSSIBILITIES



PRODUCTION:

**Ondřej Holba**

ondrejholba@protonmail.com

+420 777 867 190

TECHNICAL MANAGER:

**Martin Hamouz**

hamouz.m@gmail.com

+420 733 364 922

TOURING MANAGER:

**Nikola Křížková**

krizkova.booking@gmail.com

+420 704 870 121

**It's possible to adapt the requirements for each venue,  
but everything has to be discussed and confirmed with technical manager.**